

CLEARSTREAM™ UNIVERSAL ANTENNA MAST

Before beginning assembly, make sure all parts needed are present.

READ BEFORE INSTALLATION:

Before permanently attaching the antenna to any surface, TEST RECEPTION in that area. Connect the antenna to the TV or converter box and run a full channel scan. If reception is not as desired, move the antenna and rescan for the available channels.

Required: Power Drill, 3/16" Drill Bit, 8 and 10mm Ratcheting Drivers

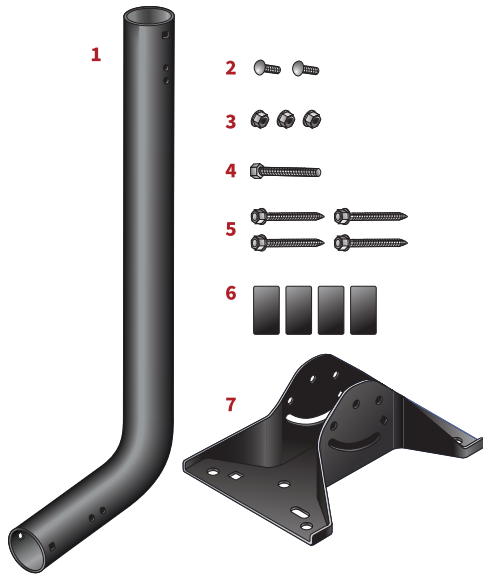

The ClearStream Universal Mast comes with:

- 1) 40" Mast
- 2) 2 - 1/4" x 1/2" Carriage Screws
- 3) 3 - 1/4" Flange Nuts
- 4) 1 - 1/4" x 2.5" Hex Screw
- 5) 4 - 1/4" x 2" Mounting Screws
- 6) 4 - Sealing Pads
- 7) Mast Base

IMPORTANT: CHECK THE RECEPTION IN THE LOCATION WHERE YOU INTEND TO INSTALL THE ANTENNA PRIOR TO ATTACHING THE MAST TO ANY SURFACE.

Before installing the antenna on the mast, adjust the mast, so it is in a vertical position. **You will need to adjust the antenna after it is mounted for the best reception.**



Warning! Keep Away from Power Lines.

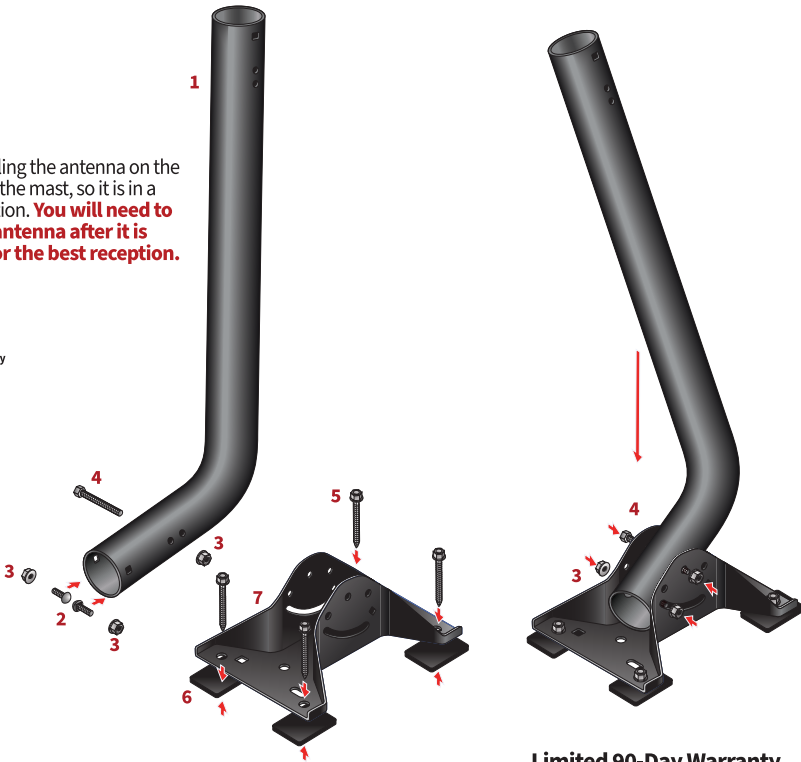

WALL MOUNT:

Mark the Mast Base (7) position on the desired surface and drill pilot holes, 1 1/2" deep, for each of the Mounting Screws (5). Place the Sealing Pads (6) over the pilot holes, and the Mast Base (7) on top of the Sealing Pads. Tighten the Mounting Screws (5).

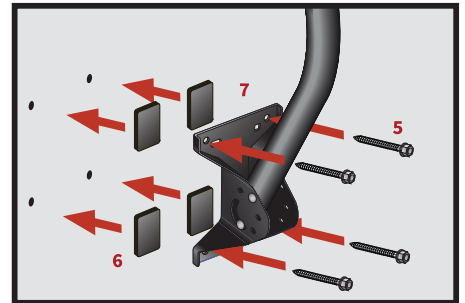

Limited 90-Day Warranty

Antennas Direct™ Inc. warrants this product against any defects in materials or workmanship for ninety (90) days. No warranty claim will be honored unless, at the time the claim is made, you present proof of purchase from an authorized Antennas Direct™ Inc. dealer.

Antennas Direct™ Inc. will either repair or replace the defective product at no charge to you. This warranty covers parts but does not cover any costs incurred in the removal or reinstallation of the product. This limited warranty does not apply if the product is damaged or fails due to: misuse, improper installation, abuse, and modification of the product as originally manufactured by Antennas Direct.

Antennas Direct™ Inc. will not assume any liabilities for any other warranties expressed or implied by any other person. The foregoing shall be the sole and exclusive remedy of any person, whether in contract, tort, or otherwise, and Antennas Direct™ Inc. shall not be liable for incidental or consequential damage or commercial loss, or for any other loss or damage, as set forth above.

16388 Westwoods Business Park, Ellisville, MO 63021, USA

©Antennas Direct
Model # MAST40
02.2024

WARNING: Lead - Cancer and Reproductive Harm
www.P65Warnings.ca.gov

TV RECEPTION CAN BE AFFECTED BY OBSTRUCTIONS OR DISTANCE BETWEEN YOUR HOME AND BROADCAST TOWERS.



Call us toll-free for technical assistance at **1-877-825-5572** or contact support@antennasdirect.com

FIND TV CHANNELS, AIM YOUR ANTENNA

antenna point

DOWNLOAD OUR FREE APP